

OPTIMAL DIMENSION GUIDE & REQUIRED INFORMATION FOR YOUR THEAM CONVEYOR INSTALLATION



To obtain optimal performance from this new THEAM conveyor unit, certain measurements and restrictions apply. Other information allows us to build your conveyor according to your specific unit for a smooth installation. It is our intention by providing this guideline that all parties involved -truck, mixer and conveyor suppliers - work toward the ultimate satisfaction of our mutual customer. Please submit proposed measurements and equipment specification information for approval. *Approval requires each page to be initialed by the appropriate party confirming the information provided.* Complete and return pages 1-5.

_____ *date sent*

_____ *customer*

_____ *date received*

_____ *principal contact* (E)

_____ (P) _____ (F)

_____ *forman* (E)

_____ (P) _____ (F)

_____ *shipping address*

_____ *billing address*

_____ *operator*

_____ *mechanic*

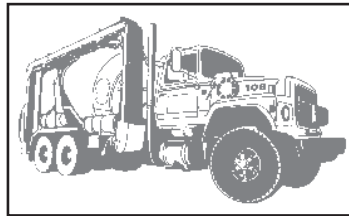
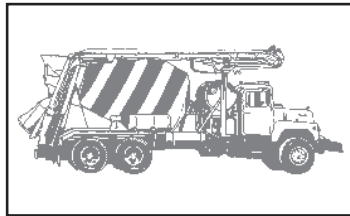
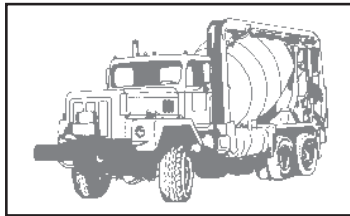
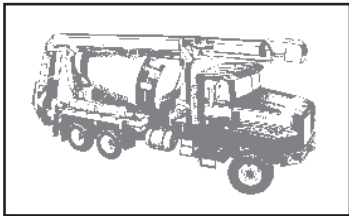
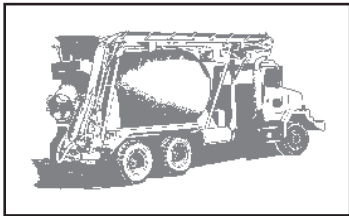

If you would like us to obtain certain information directly from your supplier, please complete the following.

Truck Supplier

_____ *company name*

_____ *contact*

_____ (P) _____ (F)

_____ (E)

Mixer Supplier

_____ *company name*

_____ *contact*

_____ (P) _____ (F)

_____ (E)

OPTIMAL DIMENSION / INFO SHEET TRUCK



Pay Attention to Properly Specing your Truck for a THEAM conveyor.
 Most THEAM conveyors work Off Road. Order the appropriate
 Rear Tandem Axle and Suspension Ratings for Off-Road use.
 Call us if you have any questions.

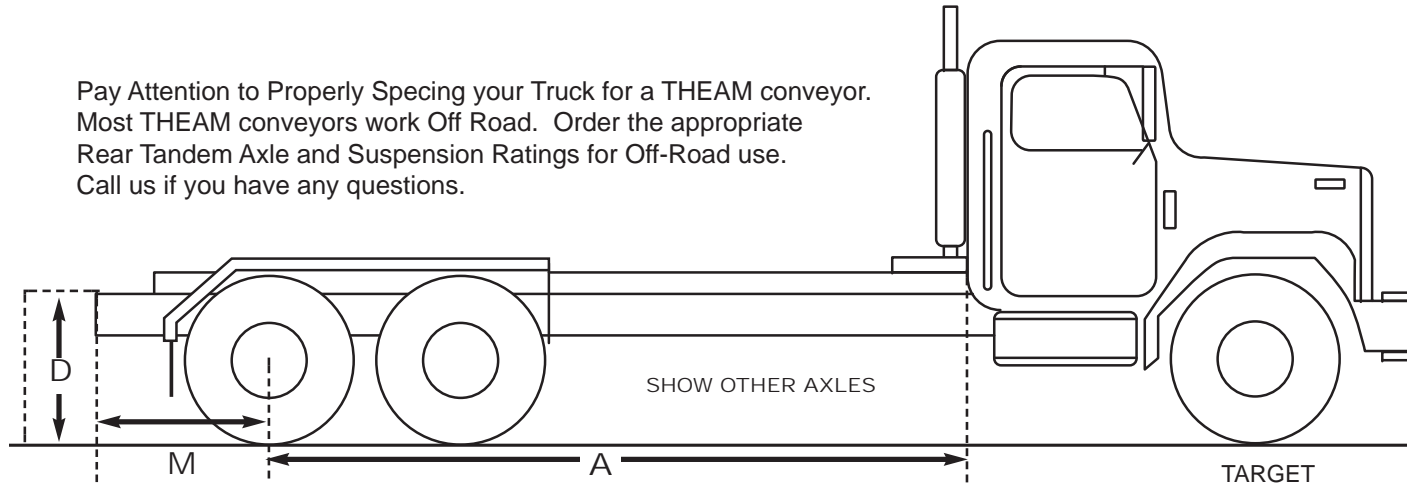

CONVEYOR MODEL: _____

TRUCK MAKE: _____

YEAR: _____

YOUR MEASUREMENTS

A	CENTER OF REAR AXLE TO BACK OF CAB	180"	
M	CENTER OF REAR AXLE TO END OF FRAME * WILL CUT AS NECESSARY	45" FRAME MIN	
D	TOP OF TRUCK FRAME TO THE GROUND (PLEASE PROVIDE)		

Digital Picture Requested if checked

- Side View
- Back View
- Behind Cab Detail

Send to: jmg@theamconveyors.com

ADDITIONAL AXLES	Y / N PLEASE DRAW IN	
REAR TANDEM AXLE RATING		
REAR TANDEM AXLE SUSPENSION RATING		
SUSPENSION MAKE/MODEL		
ENGINE MAKE/HP		
TRUCK ENGINE MINIMUM RPM@IDLE		
TRUCK ENGINE MAXIMUM RPM@WIDE OPEN THROTTLE		
TRUCK ENGINE KILL	CABLE • KEY (circle)	
ENGINE THROTTLE	CABLE • ELECTRIC • OTHER (circle)	TRANSMISSION #
ALLISON TRANSMISSION	(SEE REQUIREMENTS PG5)	
TRANSMISSION MAKE AND MODEL	(SEE NOTE PG5)	
CHASSIS FRAME	SINGLE • DOUBLE STANDARD (circle)	
FRAME DIMENSIONS	H: _____ • W: _____ • T: _____	
HAS TRUCK FRAME EVER BEEN	EXTENDED • REPAIRED (circle)	
PLASTIC FENDERS	Y / N (circle)	
PASSENGER SEAT (SEE NOTE PG. 5)	Y / N (circle)	

Initialed by: _____

Company: _____

Date: _____

OPTIMAL DIMENSION / INFO SHEET *MIXER*



	TLS	TARGET		YOUR MEASUREMENTS
		42A	42S	
A CENTER OF REAR AXLE TO BACK OF CAB	180"	175"	180"	
B END OF MIXER PEDESTAL TO CENTER OF REAR AXLE	32"	32"	32"	
C END OF TRUCK FRAME TO MIXER PEDESTAL	15"	12"	12"	
E AREA OF CONCRETE RECEPTION ON CHUTE TO TOP OF TRUCK FRAME (TO CHECK SLOPE)				

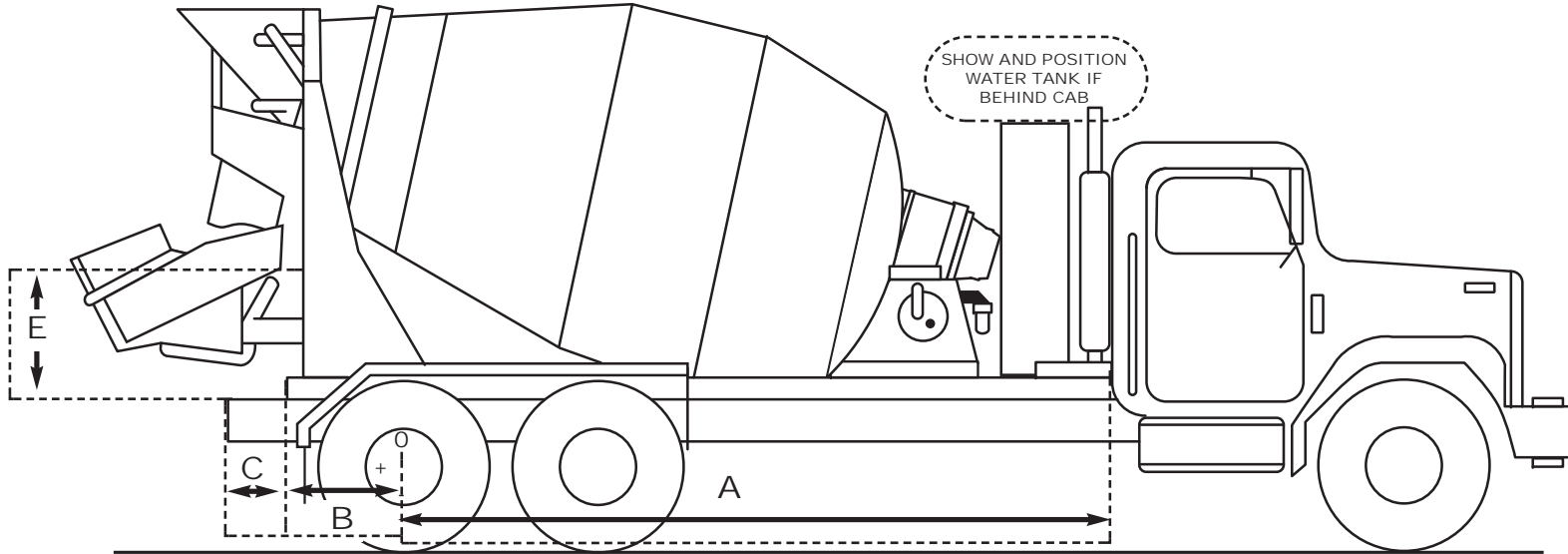

MIXER MAKE / MIXER YEAR / MIXER SIZE

PAVER = NO CONVEYOR

MIXER TYPE

STANDARD • HIGH PERFORMANCE • COMPOSITE (circle)

Digital Picture *Requested if checked*

Side View

MIXER CONTROLS

CABLE • ELECTRIC • NOT ELECTRONIC (circle)

Back View

WATER TANK LOCATION

OVERHEAD • CROSS FRAME • SIDEMOUNT (circle)

Behind Cab Detail

WATER TANK SIZE

Y / N (circle)

Send to: jmg@theamconveyors.com

KNEE BRACE

MIXER HYDRAULIC TANK LOCATION

DRAW POSITION

BOOSTER LOAD TO RAIL KIT

Y / N (circle)

Initialed by: _____

Company: _____

Date: _____

DO YOU HAVE ANY RADIO CONTROLS FOR THE MIXER?

Y / N (circle)

IF YES, WHAT BRAND

OPTIMAL DIMENSION / INFO SHEET *NOTES*

OVERHEAD WATER TANK REQUIREMENT

OVERHEAD WATER TANK HAS TO BE MOVED TO GIVE A 27" CLEARANCE FOR THE CONVEYOR.

- IF YOU DO NOT HAVE THIS CLEARANCE, MIXER SUPPLIER WILL MOVE PRIOR TO OUR ARRIVAL Y
- YOUR SHOP WILL MOVE PRIOR TO OUR ARRIVAL..... Y

Initialed by: _____

Company: _____

Date: _____

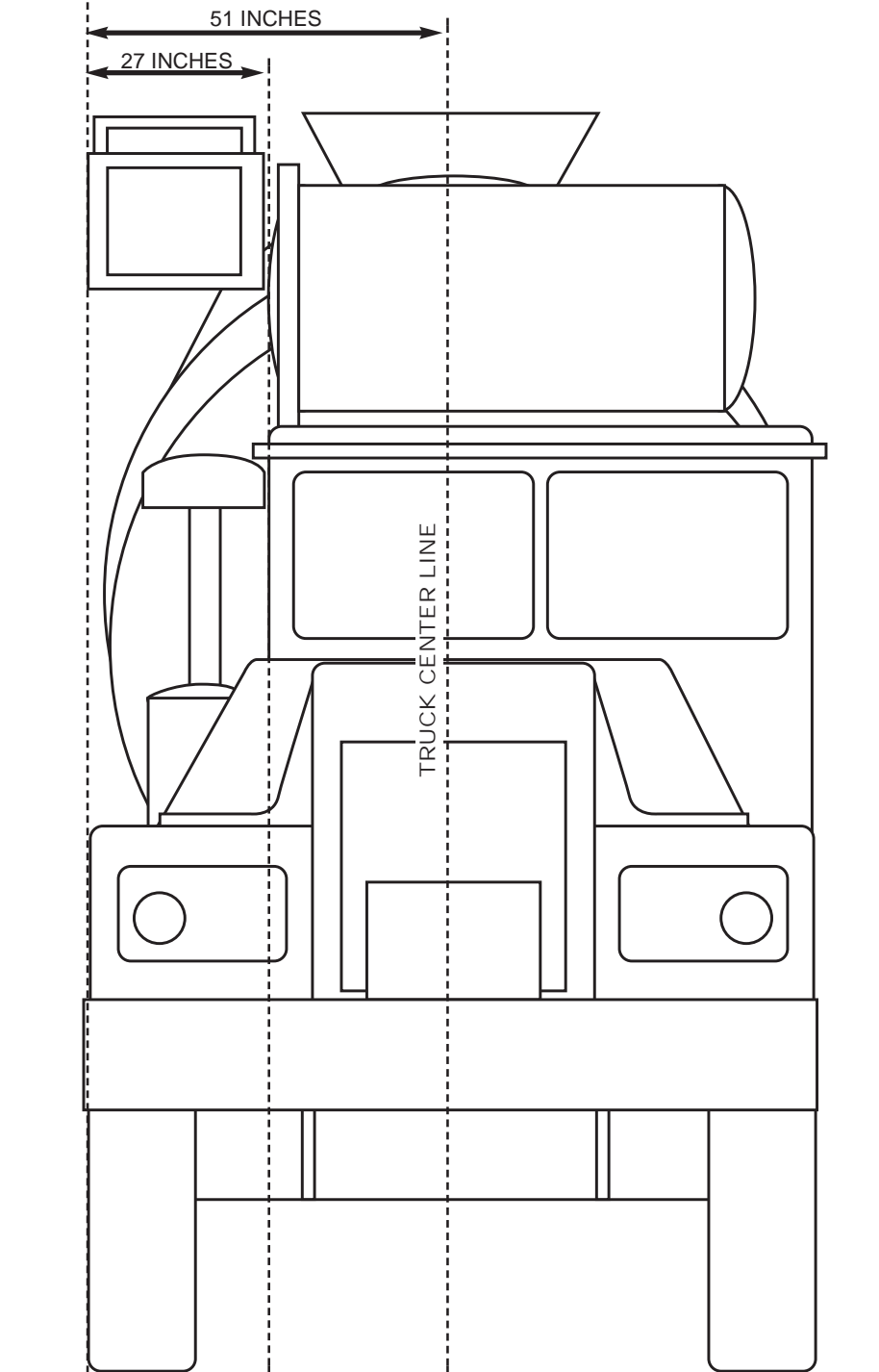

HOST TRUCK REQUIREMENTS

<input type="checkbox"/>	REAR TANDEM AXLE RATING: 44,000 LBS MINIMUM 46,000 LBS SUGGESTED Some suspension types not acceptable	
<input type="checkbox"/>	DOUBLE FRAME CHASSIS OR HEAVY DUTY FRAME	
<input type="checkbox"/>	NO DETROIT ENGINE (2 cycle engine)	
<input type="checkbox"/>	TRANSMISSION W/ PTO OPENING AND DRIVE GEAR	
<input type="checkbox"/>	IF WATER TANK IS OVERHEAD, PUSH TO DRIVERS SIDE FOR CONVEYOR CLEARANCE See sketch page_____	

ALLISON TRANSMISSIONS

REQUIRES VALUE-ADDED PTO PACKAGE

<input type="checkbox"/>	ALTERNATOR MUST HAVE AN "R" TERMINAL - SPEED CONTROL REQUIRED, ALL TL HOST TRUCKS	
<input type="checkbox"/>	6X6 OR ALL WHEEL TRUCKS MUST MOUNT MIXER PUMP OUT OF FRONT OF TRUCK	
<input type="checkbox"/>	SPECIFY IF YOU HAVE REAR-MOUNTED TRANSMISSION OIL COOLER - SPECIAL PTO NECESSARY	

MIXER REQUIREMENTS

<input type="checkbox"/>	DO NOT USE "PAVER" OR LOW PROFILE MIXER	
<input type="checkbox"/>	MIXER SIZE: 9 1/2 TO 11 CU. YD.	Specify Mixer Mfg.- some restrictions apply
<input type="checkbox"/>	NO BOOSTER OR TAG AXLES (push axles ok)	
<input type="checkbox"/>		

CAUTION/NOTES

- * WITH CONVEYOR INSTALLED, YOUR TRUCK OVERALL HEIGHT WILL BE BETWEEN 12'10" AND 13'4"
- * LIST WHAT MODULES WILL BE INCORPORATED IN YOUR MIXER / TRUCK INTERFACE. WE MAY NEED TO HAVE YOU DISCONNECT DURING INSTALLATION TO AVOID INTERFERENCE / DAMAGE.
- * 15% RESTOCKING FEE ON PTO'S. DOUBLE CHECK THOSE TRANSMISSION NUMBERS. THANKS.
- * WE CAN INSTALL OUR ELECTRONIC PANEL IF YOU OPT OUT OF PASSENGER SEAT. IT PROVIDES EASY ACCESS FOR SERVICING.

Initial _____
 Company: _____
 Date: _____

<p>HOST TRUCK APPROVAL</p> <p>• COMMENTS: _____</p> <p>• WESTCON MFG INC APPROVAL BY _____ DATE: _____</p>	<p>• YES / NO</p>
-------------------------------------------------------------------------------------------------------------------	-------------------